

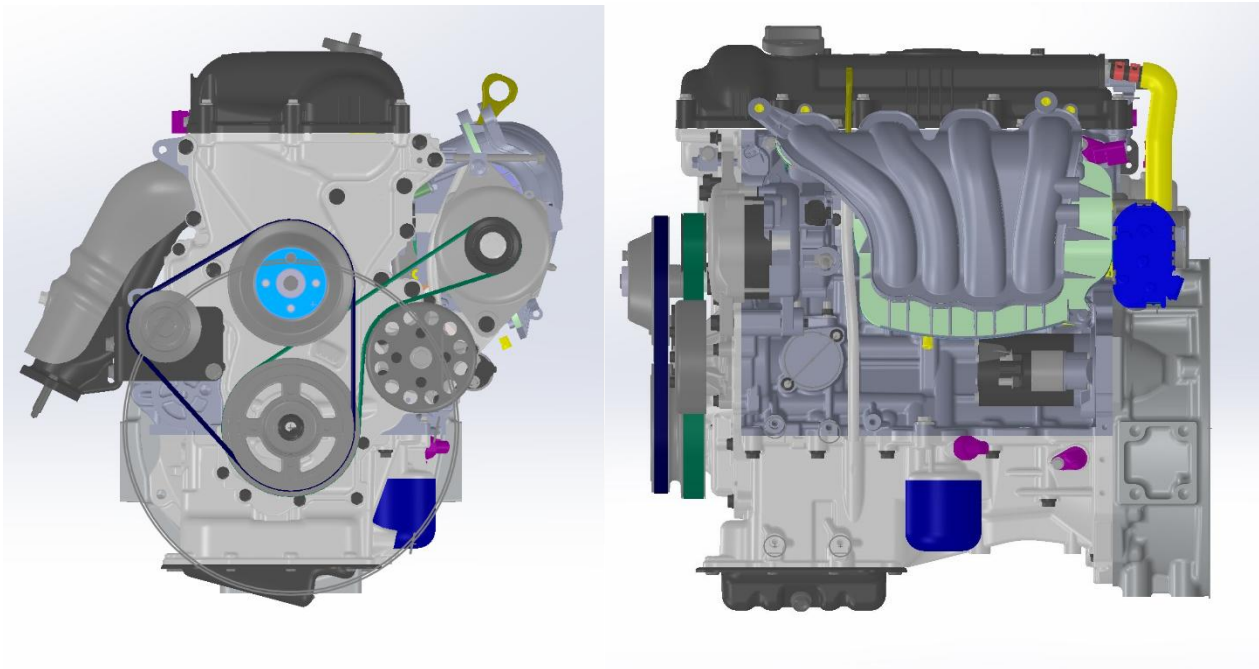

Purpose Built Industrial Engines Powering Industry

WARRANTY POLICY

Stationary & Constant-Speed Mobile Industrial Engines
Continuous and Emergency Standby



Zenith Power Products, LLC is an integrator of Quality Purpose-Built Industrial Engines.

Our focus is to provide the industrial engine user with consistent performance, service, and reliability.

This document has been published for the purpose of supporting ZPP’s Distributors and as a tool to assist the end-user in obtaining service for ZPP products.

This Policy applies to all Zenith Power Products engines.

For Emission Warranty, refer to the standalone document included with your engine package, or visit our website; www.zenithpp.com.

CONTENTS

Services Provided	3
Warranty Responsibility	4
Warranty Terms	6
Warranty Claims	8
Audit Policy	12
Limited Warranty Statement and Owner’s Responsibilities	13

Services Provided

- Provide technical training to distributors and authorized agents.
- Assist in solving extraordinary customer service issues.
- Assist with parts needed.
- Provide applications review for new applications.

Publications

- Operators' manual
- Workshop manual
- Installation diagrams
- Service parts list
- Service bulletins

Genuine ZPP Parts

ZPP provides genuine service parts for repair and maintenance of its engines. It is recommended to utilize only genuine ZPP parts. The use of genuine ZPP parts is mandatory when warranty repair is performed. Installing non-genuine ZPP parts will result in voiding warranty.

Special Troubleshooting Tools

Diagnostic software interface kits can be purchased from ZPP. Please contact the customer services or sales departments for more details.

Training

ZPP will provide the necessary training throughout our distributors upon request. Distributors are responsible for setting up training through ZPP's customer service department. Special training classes can be arranged with ZPP. Please contact customer service for information.

Warranty Responsibility

Introduction

The Warranty described here is from Zenith Power Products, LLC, and will here tofore be referred to as ZPP in this document. This is a limited warranty that is provided to the retail purchaser in return for consideration as part of the purchase of one of Zenith Power Product's engines. At time of sale both selling distributors and retail purchaser shall agree to, sign, and date the Warranty and Limitation of Liability Agreement and Product Registration. This signed agreement and registration must be sent to Zenith Power Products LLC by mail or email.

Zenith Power Product's Responsibility

If a defect in material or workmanship is found on a Zenith Power Product's engine and reported during the warranty period, Zenith Power Products will pay parts and labor costs to repair the defect if the services are completed by an authorized Zenith Power Product's distributor. Zenith Power Products is responsible for determining what is covered under the Limited Liability Warranty of the engine and what is the original owner's responsibility.

Zenith Power Product's warranty is limited to the terms of this document. Zenith Power Products does not authorize any person, dealer, or agent to change the terms of this warranty in any manner. "This limited warranty is exclusive and in lieu of all other warranties and representations, expressed, implied, or statutory, whether written or oral, including but not limited to any warranty of merchantability or fitness for any particular purpose, and any implied warranty arising from any course of performance or dealing or trade usage. This warranty is also in lieu of any other obligation, liability, right or claim, whether in contract or in tort, including any right arising from negligence on the part of Zenith, and Zenith's liability on such claims shall in no case exceed the price of the product. In no event, whether because of a breach of warranty, contract, or alleged negligence, shall Zenith be liable for special or consequential or any other damages, including but not limited to loss of profits, or revenues, loss of use, or cost of a replacement. "

Zenith Power Products responsibilities include, but not limited to:

- Deliver an engine free of defects in material and workmanship.
- Reimburse costs for repairs that are a result of defects in material and workmanship.
- Provide warranty payment to dealers in a timely manner.
- Identify engine deficiencies and provide corrective action.
- Make determinations of premature wear.
- Provide operators manuals.

This warranty is void if:

- Engine has not been registered within 10 working days after retail. (Not applicable for Emission Warranty)
- The hour meter has been changed or altered.
- The engine's components have been modified beyond specifications.
- Engine is used in an application not designed for.

Engine has been stolen, scrapped, or discarded.

Distributor's Responsibility includes, but not limited to:

- Receiving, inspecting, and documenting shortages.

- Selling the correct engine for the intended application.
- Reviewing operator's manual with the customer.
- Instructing customers on proper use and engine maintenance.
- Advising and explaining warranty coverage to the customer at time of sale.
- Completing the Zenith Power Products engine registration form.
- Diagnosing the problem, repairing the unit, and applying for warranty if eligible.
- Explaining non warranty repairs to the customer.
- Submitting complete warranty claims
- Service documents or Work orders must include:
 - Make, Model, Serial #, Hours of Use, Complaint, Cause, Correction.
 - Opened immediately on the date of notification of a failure.
 - One work order per failure.
 - Submitted to ZPP no more than 30 days from last date of repair.
 - Responding to denial notice, RMA, or request of additional information within 30 days.
 - Warranty parts are properly stored, tagged, and held onto for 60 days before discarding.
 - Fully stocking necessary maintenance and repair parts for engines sold.
- Provide fully equipped service shop with qualified personnel, diagnostic tools, and service manuals.

Distributor Responsibility on Non-Warranty Failure

Failures due to lack of maintenance, environmental conditions, accidents, misuse, or failing to follow recommended ownership procedures found in the Operators Manual will have effects on engine performance and longevity. Failures found by these causes will not be recognized for warranty compensation.

The distributor's responsibility to ask the appropriate questions before deeming a repair warrantable. If the distributor commits to a customer that a repair is warrantable, reviewed by Zenith Power Products, and is denied, the distributor shall absorb the cost of the repair or bill the customer.

Original Owner's Responsibility

Warranty is recognized during the stated warranty period so long as the owner performs the required maintenance at the recommended times stated in the operator's manual. The owner will pay for all transportation expenses related to warranty repairs.

Owner's responsibilities include, but are not limited to:

- Performing maintenance as recommended in operator's manual.
- Using unit in the application intended.
- Using unit in a non-abusive manner.
- Notifying distributor of failures and having engine available for repair in a timely manner.
- Training operators.
- Paying for additional service call or transportation charges.
- Paying for normal wear or maintenance items.
- Paying for accidental machine damage.

Inspecting and adjusting of engine.

Warranty Terms

Introduction

Zenith Power Products will, at our option, repair or replace any component covered under this warranty policy that becomes defective during normal use and operation within the terms and time limits specified.

Warranty period: Base warranty coverage (whichever comes first)

Rating	Months	Hours
Stationary and Constant Speed Mobile	12	2500
Variable Speed Mobile	24	2000
Emergency Standby	24	400
HDI 424	36	3000
HDI 434	36	3000

- Stationary or Constant Speed Mobile – Means compressor applications, irrigation applications, or generator sets operating at a constant speed.
- Variable Speed Mobile Applications – Means foot pedal-controlled equipment such as ground support vehicles.
- Emergency Standby – Means engines operated to provide electrical or mechanical work (such as electrical power or pumping water) during an emergency situation and not exceeding 100 hours per calendar year non-emergency service per, EPA 40 CFR 60.4248.

Original Purchasers

The warranty to the original retail customer commences at the selling date of the product by the distributor or by the OEM customer. This warranty shall be in effect for the period as stated on the printed warranty certificate.

Items Not Covered by Warranty

- Engine applications not approved through ZPP’s application process, or not properly registered.
- Costs with performing an arrival report, pre-delivery inspections, or from excessive storage.
- Repairs necessary to correct any failures due to improper pre-delivery service and inspection of selling distributor.
- Engines that have been subjected to alteration, modification, neglect, unauthorized repairs, or any engine applied to any application not approved by ZPP.
- Engines suffering shipping or freight damage, normal wear, accident, improper maintenance of improper protection in storage or storage deterioration.
- Rental costs, costs of transportation of products to OEM, Distributor/Service Center, phone communications, or other costs associated with the shipment of the product.
- Repairs made necessary due to additions or modifications not authorized or recommended by ZPP.
- Repeat of shop come-back repairs resulting from poor service work, improper diagnosis or testing.
- Replacement parts other than those sold by ZPP as original equipment.
- Any normal replacement and/or service of injectors, pumps, vaporizers, regulators, the checking and/or replacement of parts failure due to impurities in the fuel: routine fuel system maintenance and fuel/oil filter replacement.

Items Not Covered by Warranty – cont.

- Natural calamity or acts of God such as fire, flood, or by accident, vandalism, etc.
- Damage to all internal and external engine components, including electrical, or electronic components caused by water, moisture, or the environment.
- Normal maintenance services such as engine tune ups, engine fuel system cleaning, checks, adjustments, shimming, spark plugs, fuses, etc.
- Gaskets not claimable as a causal part or point of failure.
- Parts and Services performed due to distributor or customer’s demand.
- Labor charges performed by anyone other than an authorized Zenith distributor, unless previously authorized by Zenith.
- All travel expenses for transportation of engine from customer’s location to servicing distributor.
- Zenith engines sold “as is” basis and is notified to customer at time of sale.
- Starter motors and alternators used in extreme heavy duty and repeated start applications unless pre-approved by Zenith Power Products will be warranted for 6 months or 750 hours, whichever comes first.
- Engines consuming oil will not be considered warranty unless oil usage exceeds standards listed in the table found below.
- Electrical components damaged because of welding or jump-starting.
- Replacement of items during a warrantable repair such as: coolant, oil, oil filters, fuel filters, fan belts, fuses, and similar consumable parts. Replacement of these parts is the owner’s responsibility unless the item was damaged or not reusable.
- The replacement of complete assembly, unless approved by ZPP.
- Damage caused by contaminated oil, incorrect oil change intervals, incorrect viscosity, bad or contaminated fuel, or the use of starting agents.
- Pressure or steam cleaning products, cleaning of fuel systems, flushing of cooling systems, or solvent chemicals used to clean out lubrication systems while engine is running or intact.

H2O, H2S, and CO2, Acceptable Limits in Fuel Gas for ZPP Engines

Compound	H2O	H2S	CO2
Limit	10°F below local dew point temperature	20 ppmv	3.00%

Zenith Maxium Oil Consumption

Data based upon national automotive and industrial average.

Oil consumption per 24 hr. operation based on 0.120 qts/day/liter.		
Engine Family	Cubic Capacity	Total Acceptable Usage
416	1.6L	0.192 qt/24hrs
424	2.4L	7.0 grams/hr
434	3.4L	10.0 grams/hr
665	6.5L	0.78 qt/24 hr
690	9.0L	1.08 qt/24hr
6120	12.0L	1.44 qt/24hr

Warranty Claims

Submitting Claims

Warranty claims submitted by distributors must include a fully completed Zenith Power Products Warranty Claim form, a copy of the work order, and a copy of the engine invoice. Claims will not proceed to processing without these three documents. When submitting a claim, the following information is required:

- Customer name.
- Explained Complaint, Cause, and Correction.
- Make, Model, Serial number, number hours of use.
- Causal part.
- Failure date.
- Repair date.
- Purchase date.
- Parts installed.
- Labor amount requested.
- A travel allowance of up to \$200 is offered for service calls based on time/shop rate.

Warranty claims must be submitted within 30 days from the date of repair work/tech time punch, not the date the work order was closed. Claims submitted past 30 days will be denied. Warranty claims missing information as stated above will be returned to that dealer's warranty administrator and allowed the chance to make corrections. If 30 days pass from return of claim notice, claim will be denied. One service document or work order per warranty claim. Multiple service documents or work orders per warranty claim will not be recognized.

Warranty claims above \$5000 dollars must include:

- Copy of original work order (print 1)
- Photos of failure
- Technician time report

Warranty Labor

Warranty labor is the amount of time billed to the service document or work order, unaltered. Labor time is not to be moved to a different document and can result in a charge back in the total amount if discovered during an audit. Labor rates or discounted time for customer paid service work will also be extended to ZPP Warranty and will be recognized when adjusting posted labor rate amount. Labor rate can only be increased once within a calendar year and is only subject to manufacturer approval. Shop rates will be recognized, and, if needed to be changed, the following procedures must take place:

- One-month notification to ZPP of the labor rate changes.
- Posted labor rate.
- Three customer-paid work orders verifying the change.

Non-Warranty Labor

ZPP will provide customer service diagnostic or repairs on any ZPP's engines that are out of warranty. The charges will be paid by the customer upon completion of repair, considering parts, shipment costs, phone calls, technical diagnostics, service labor at (\$85.00/hour) and any other expenses related to the repair.

Warranty Parts

Parts will be provided by ZPP and reimbursed at cost. At the time of ordering parts, provide a work order number or parts counter invoice number. Parts will not be issued without a work order or part invoice number. If the use of non-ZPP parts is necessary, ZPP must authorize it and parts will be billed at cost with receipts provided. ZPP over the counter parts sale come with a 60-day part warranty. Part warranty starts the day of part sale as documented on customer's invoice.

Exclusion to the part warranty:

- The engine is no longer in production and will be notified at the time of part sale.
- Part is no longer in production and will be notified at time of part sale.
- Electrical components were removed from packaging.

Parts Defective from Inventory

Service parts found to be defective but have not been used can be returned for a part exchange or refund. ZPP will issue an RMA and part will be sent back for evaluation. Any labor, travel, or freight does not apply to parts sold over the counter.

Warranty Part Returns

Warranty parts are to be properly tagged and stored for 60 days.

Parts changed under ZPP's warranty are eligible for part evaluation and must be returned if requested. An RMA will be provided, and the distributor has up to 30 days to return failed component. ZPP will proceed with the warranty claim processing, issue a credit if deemed warranted, and once received send failed component off for evaluation. If evaluation deems part as failed credit remains, if part proves to be in working order a debit notice will be issued with an explanation. Claim reversal occurs when:

- Parts requested are not returned or returned after 30 days of notice.
- Parts returned are not the parts on the service document that is being claimed.
- Parts are damaged due to improper or inadequate packaging.
- Parts are not properly tagged.
- Parts are tested and are not found to be defective.

Warranty Claim Appeals

If the distributor wishes, warranty claims that have been satisfied can be appealed within 30 days of receiving the credit memo, denial, or debit notice. Claims appealed beyond 30 days of these notices will be denied. At time of appealing, additional information is required, and claims that are submitted with same information will be rejected.

Repairs made beyond the Warranty Expiration Date

Completion of a warrantable repair that passes engine's warranty expiration date will be considered when these conditions are met:

- Original work order (print 1) is opened before the engine's warranty expiration date.
- A copy of the original work order is sent at time of initial Zenith Warranty Claim submission.
- Technician time punches or labor records are provided.
- An explanation when over 30 days of expiration date has been passed.
- Work orders generated after the warranty expiration date will be deemed as non-warranty and are placed on the servicing distributor or customer's financial obligation.

WARRANTY CLAIM FORM

This form is to be used by a Distributor or Authorized Agent's customer as the Warranty Claim submission for Engines, Fuel Systems or Accessories. The form should be filled out entirely to ensure timely processing of the warranty claim. Claims submitted incomplete will be returned and could delay the claim process. To submit a claim, it is necessary to email it to warranty@zenithpp.com or mail it to ZPP Warranty Department.

Damage and Shortage Policy

Products received by Distributor or Authorized Agent in a damaged condition must have the damage noted on the bill of lading and/or the freight bill. A claim must be immediately filed with the common carrier that delivered the shipment.

If a Distributor or Authorized Agent used his own truck or have arranged the carrier transportation to pick up the engine from ZPP's facility, the damage must be noted on the bill of lading prior to leaving ZPP's facility for ZPP to be responsible for the damage. Damage that occurs in transit is the responsibility of the Distributor or Authorized Agent.

Engines or accessory kits that have missing parts or improper fit should be reported to ZPP immediately upon receipt. Pictures or other information will be helpful for ZPP to process the claim.

Warranty Claim Forms

Zenith Warranty claim form is found by logging on to Zenith Power Product's, LLC website, www.zenithpp.com, hover over Service/Warranty, click on Warranty, and Fillable Claim Form for Distributors. See example below.

Audit Policy

In agreement of the ZPP's Warranty Policy, distributors shall permit persons designated by ZPP to examine, copy, and audit all distributor's records and documents relating to Zenith Warranty. Verification is required to show that service documents/work orders were properly opened, claims were accurately documented, and proper compensation was provided under the terms of Zenith Warranty.

The following records must be provided at time of audit:

- Work order records
 - Original (print one) open and closed
 - Customer name
 - Make, Model, and Serial Number
 - Hours of use
 - Customer complaint, cause, and correction
 - Labor and Parts applied
- Parts Records
 - Documentation of parts used in repair were purchased from ZPP
 - Parts history
- Labor Records
 - Specific technician(s)
 - Dates
 - Starting and ending times
 - Able to cross reference labor times to service document or work order
 - Technician's paid hours for repair
- Technician's description of repair
 - Description of cause of failure
 - Description of labor and parts required to complete repair
 - Ability to cross reference Technician to service document or work order
- Outside services or parts used
 - Original invoice from outside services or parts
 - Proof of payment to outside service or part purchases
- Accounting Records
 - Dates parts were paid for
 - Labor hours worked/paid



ENGINE LIMITED WARRANTY

Zenith Power Products LLC (ZPP) will, at our option, repair or replace any component covered under this warranty that becomes defective during normal use and operation within the terms and time limits specified.

Definition: As used in this warranty, “Engine Package (Assembly)” means a new ZPP Engine equipped with an emissions compliant fuel delivery system and exhaust after treatment device, sold by ZPP to an OEM manufacturer or delivered by an authorized ZPP engine Distributor (“Seller”) to the original retail purchaser.

The emissions related warranty covers only components for certified engines whose failure would increase the engine emissions. The replacement or repair of other components not supplied by ZPP is the owner’s responsibility.

Application review: ZPP cannot anticipate all potential field issues. The engine package application must be approved by ZPP through our application review process. Machine field and/or lab durability testing by the OEM is critical to further reduce the potential for field failures. Only those parts approved by ZPP, fuel delivery system and exhaust after treatment device will be considered in this warranty. Other accessories supplied by ZPP such as: radiator, brackets, hoses, back ends, etc. will follow the original warranty per the part manufacturer.

Warranty: Provided products are operated and maintained in accordance with Zenith’s written instructions, ZPP warrants to the original retail purchaser that the Seller, on behalf of ZPP, will, during the warranty period, repair or replace (at ZPP’s option) any engine parts which are defective in factory-supplied materials and workmanship. *Engines operating outside of North America are covered on a parts replacement basis only. ZPP prior approval is required for all warranty repairs.*

The warranty period shall begin when the engine is delivered to the ultimate purchaser. Operating hours will be determined by the Engine Control Module’s (ECM’s) internal hour meter.

Warranty period: Base warranty coverage (Whichever occurs first):

Rating	Months	Hours
Stationary and Constant Speed Mobile	12	2500
Variable Speed Mobile	24	2000
Emergency Standby	24	400

- **Stationary or Constant Speed Mobile-** Means compressor applications, irrigation applications, or generator sets operating at a constant fixed speed.
- **Variable Speed Mobile Applications-** Means foot-pedal controlled equipment such as ground support vehicles.
- **Emergency Standby-** Means engines operated to provide electrical or mechanical work (such as electrical power or pumping water) during an emergency situation and not exceeding 100 hours per calendar year non-emergency service per, EPA **40 CFR 60.4248**

Obtaining Warranty Service:

To obtain warranty repairs, you must contact the Seller within 30 days, who shall determine warranty consideration and perform the repair, following the **ZPP** Warranty Policy Guidelines.

At the time of requesting warranty service, the purchaser must be prepared to present evidence of the engine's delivery date. ZPP reimburses authorized service outlets for limited travel expenses incurred in warranty repairs when travel is required. Contact your servicing dealer for current travel reimbursement limits. If distances and travel times are greater than travel expenses authorized by ZPP, the servicing dealer may charge the purchaser the difference.

Exclusions:

- A. In no event, shall ZPP be liable for loss of time, inconvenience, loss of use of the Engine package, damage to persons or property, or any other incidental or consequential damage. In no event, shall the maximum liability of ZPP under this warranty exceed the purchaser's cost of the Engine.
- B. The obligation and liability under this warranty is limited to the repair or replacement, at the option of ZPP, of any engine parts, components, or the Engine Package. The warranty does not provide for any labor, travel expenditure, or incremental costs associated with product removal and reinstallation associated with defective parts, components, or Engine Package except where required by law.
- C. This warranty does not cover:
 - 1) Any failures related to an application not approved by ZPP.
 - 2) Any parts or accessories installed on the Engine package which were not manufactured or installed by **ZPP** (including, without limitation, manifolds, batteries, alternators or starters). Such parts and accessories may be covered by a warranty from the manufacturer of said item.
 - 3) Any defect in the Engine package which was caused (in ZPP's sole judgment) by other than normal use and service or by any misuse, negligence, fuel contamination, overloading, accident, abuse, alternation, unsuitable storage, immersion or submersion, or use other than in accordance with the Engine's rated capacity and use.
 - 4) Any adverse effect on the Engine package caused by repair by other than an authorized ZPP repair facility or with parts or supplies not manufactured or supplied by ZPP.
 - 5) Any Engine whose serial number has been altered or removed or on which recommended maintenance and inspections have not been performed.
 - 6) Normal maintenance and inspection, such as tune-up, tightening of nuts, bolts, screws, replacement of belts, etc.
 - 7) Selection or installation of the Engine package for its intended use, if performed by someone other than the Seller.

No Seller's Warranty

No person or entity, other than Zenith Power Products, who sells the engine or product in which the engine has been installed makes any guaranty or warranty of its own on any engine warranted by Zenith Power Products unless it delivers to the purchaser a separate written guaranty certificate specifically guaranteeing the engine, in which case Zenith Power Products shall have no obligation to the purchaser. Neither original equipment manufacturers, engine or equipment distributors, engine or equipment dealers, nor any other person or entity, has any authority to make any representation or promise on behalf of Zenith Power Products or to modify the terms or limitations of this warranty in any way.

DISCLAIMER OF IMPLIED WARRANTIES:

THIS IS THE ONLY WARRANTY WHICH ZPP MAKES FOR THE ENGINES PACKAGES. ALL IMPLIED WARRANTIES, INCLUDING WARRANTIES OF MERCHANTABILITY AND WARRANTIES OF FITNESS FOR A PARTICULAR PURPOSE, ARE SPECIFICALLY EXCLUDED.

"THIS LIMITED WARRANTY IS EXCLUSIVE AND IN LIEU OF ALL OTHER WARRANTIES AND REPRESENTATIONS, EXPRESS OR IMPLIED OR STATUTORY, WHETHER WRITTEN OR ORAL, INCLUDING BUT NOT LIMITED TO ANY WARRANTY OF MERCHANTABILITY OR FITNESS FOR ANY PARTICULAR PURPOSE, AND ANY IMPLIED WARRANTY ARISING FROM ANY COURSE OF PERFORMANCE OR DEALING OR TRADE USAGE.

THIS WARRANTY IS ALSO IN LIEU OF ANY OTHER OBLIGATION, LIABILITY, RIGHT OR CLAIM, WHETHER IN CONTRACT OR IN TORT, INCLUDING ANY RIGHT IN STRICT LIABILITY IN TORT OR ANY RIGHT ARISING FROM NEGLIGENCE ON THE PART OF ZENITH, AND ZENITH'S LIABILITY ON SUCH CLAIMS SHALL IN NO CASE EXCEED THE PRICE OF THE PRODUCT.

IN NO EVENT, WHETHER AS A RESULT OF A BREACH OF WARRANTY, CONTRACT OR ALLEGED NEGLIGENCE, SHALL ZENITH BE LIABLE FOR SPECIAL OR CONSEQUENTIAL OR ANY OTHER DAMAGES, INCLUDING BUT NOT LIMITED TO LOSS OF PROFITS OR REVENUES, LOSS OF USE, OR COST OF A REPLACEMENT."

ENGINE MODEL

ENGINE SERIAL NUMBER

CUSTOMER NAME

TYPE OF EQUIPMENT

DELIVERY DATE

CUSTOMER CITY, STATE, ZIP

MAKE/MODEL/VIN/SERIAL NUMBER

DISTRIBUTOR NAME

CUSTOMER SIGNATURE

MANUFACTURE'S NAME

IMPORTANT NOTE:

All the above information must be completed before filing with Zenith Power Products to ensure warranty registration can be activated. You can also register your engines online at www.zenithpp.com.

Please return the original signed documents to:

ZENITH POWER PRODUCTS

227 Oneida Dr

Tomahawk, WI 54487

ATTN: CUSTOMER SERVICE DEPARTMENT

IMPORTANT!

Please return this document to ZPP Customer Service Department or register online at www.zenithpp.com within 10 (ten) working days after the equipment sale.